



TESTED TOUGH

HD

Hollow Pin

(All dimensions listed in inches)

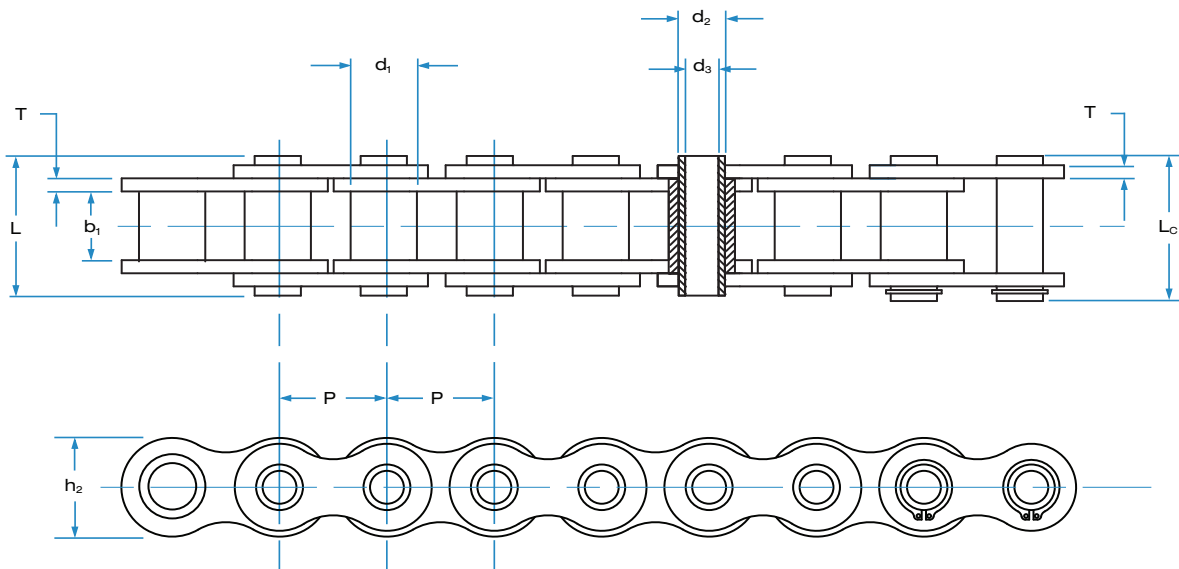

Chain Number	Pitch	Roller Diameter	Width Between Inner Plates	Hollow Pin Outside Diameter	Hollow Pin Inside Diameter	Hollow Pin Length		Inner Plate Height	Plate Thickness	Min. Ultimate Tensile Strength (lbs)	Average Tensile Strength (lbs)	Max Working Load (lbs)	Weight per Foot (lbs/ft)
	P	d_1 max	b_1 min	d_2 max	d_3 max	L max	L_c max	h_2 max	T max				
HD40 HP RIV	0.500	0.312	0.312	0.222	0.157	0.65	0.69	0.47	0.060	2,500	2,743	319	0.4
HD50 HP RIV	0.625	0.400	0.375	0.277	0.202	0.81	0.86	0.59	0.080	4,545	5,081	652	0.6
HD60 HP RIV	0.750	0.469	0.500	0.327	0.236	1.02	1.06	0.71	0.094	5,455	6,047	730	0.9
HD80 HP RIV	1.000	0.625	0.625	0.449	0.317	1.28	1.33	0.94	0.125	11,364	11,690	1,551	1.5